

Grizzly
Industrial, Inc. ®

RADIAL DRILL PRESS
MODEL G7945/46
INSTRUCTION MANUAL



COPYRIGHT © 2001 BY GRIZZLY INDUSTRIAL, INC.
WARNING: NO PORTION OF THIS MANUAL MAY BE REPRODUCED IN ANY SHAPE
OR FORM WITHOUT THE WRITTEN APPROVAL OF GRIZZLY INDUSTRIAL, INC.
JUNE, 2001 PRINTED IN CHINA.

WARNING

Some dust created by power sanding, sawing, grinding, drilling, and other construction activities contains chemicals known to the State of California to cause cancer, birth defects or other reproductive harm. Some examples of these chemicals are:

- Lead from lead-based paints.
- Crystalline silica from bricks, cement, and other masonry products.
- Arsenic and chromium from chemically treated lumber.

Your risk from these exposures varies, depending on how often you do this type of work. To reduce your exposure to these chemicals: work in a well ventilated area, and work with approved safety equipment, such as those dust masks that are specially designed to filter out microscopic particles.

Table Of Contents

	PAGE
1. SAFETY	
SAFETY RULES FOR ALL TOOLS	2-3
ADDITIONAL SAFETY INSTRUCTIONS FOR G7945/46	4
2. CIRCUIT REQUIREMENTS	
110V OPERATION	5
GROUNDING	5
EXTENSION CORDS	5
3. INTRODUCTION	
COMMENTARY	6
UNPACKING	7
PIECE INVENTORY	7
CLEAN UP	8
SITE CONSIDERATIONS	8
4. ASSEMBLY	
BEGINNING ASSEMBLY	9
COLUMN/BASE	9
TABLE SUPPORT	10
HEADSTOCK	11
HANDLES	11
DRILL CHUCK AND ARBOR	11
5. ADJUSTMENTS	
SPEED CHANGE	12
DEPTH STOP	13
TABLE ADJUSTMENTS	14
HEAD ADJUSTMENTS	15
6. OPERATIONS	
TEST RUN	16
DRILL BIT CHANGES	16
7. MAINTENANCE	
GENERAL	17
TABLES	17
LUBRICATION	17
V-BELT	17
8. CLOSURE	18
MACHINE DATA	19-20
PARTS BREAKDOWN AND PARTS LISTS	21-22
WARRANTY AND RETURNS	24-25

SECTION 1: SAFETY

WARNING

For Your Own Safety Read Instruction Manual Before Operating This Equipment

The purpose of safety symbols is to attract your attention to possible hazardous conditions. This manual uses a series of symbols and signal words which are intended to convey the level of importance of the safety messages. The progression of symbols is described below. Remember that safety messages by themselves do not eliminate danger and are not a substitute for proper accident prevention measures.



Indicates an imminently hazardous situation which, if not avoided, **WILL** result in death or serious injury.



Indicates a potentially hazardous situation which, if not avoided, **COULD** result in death or serious injury.



Indicates a potentially hazardous situation which, if not avoided, **MAY** result in minor or moderate injury. It may also be used to alert against unsafe practices.

NOTICE

This symbol is used to alert the user to useful information about proper operation of the equipment.

WARNING

Safety Instructions For Power Tools

- 1. KEEP GUARDS IN PLACE** and in working order.
- 2. REMOVE ADJUSTING KEYS AND WRENCHES.** Form habit of checking to see that keys and adjusting wrenches are removed from tool before turning on.
- 3. KEEP WORK AREA CLEAN.** Cluttered areas and benches invite accidents.
- 4. DO NOT USE IN DANGEROUS ENVIRONMENT.** Don't use power tools in damp or wet locations, or where any flammable or noxious fumes may exist. Keep work area well lighted.
- 5. KEEP CHILDREN AND VISITORS AWAY.** All children and visitors should be kept a safe distance from work area.
- 6. MAKE WORKSHOP CHILD PROOF** with padlocks, master switches, or by removing starter keys.
- 7. DO NOT FORCE TOOL.** It will do the job better and safer at the rate for which it was designed.
- 8. USE RIGHT TOOL.** Do not force tool or attachment to do a job for which it was not designed.

WARNING

Safety Instructions For Power Tools

- 9. USE PROPER EXTENSION CORD.** Make sure your extension cord is in good condition. Conductor size should be in accordance with the chart below. The amperage rating should be listed on the motor or tool nameplate. An undersized cord will cause a drop in line voltage resulting in loss of power and overheating. Your extension cord must also contain a ground wire and plug pin. Always repair or replace extension cords if they become damaged.

Minimum Gauge for Extension Cords

AMP RATING	LENGTH		
	25ft	50ft	100ft
0-6	18	16	16
7-10	18	16	14
11-12	16	16	14
13-16	14	12	12
17-20	12	12	10
21-30	10	10	No

- 10. WEAR PROPER APPAREL.** Do not wear loose clothing, gloves, neckties, rings, bracelets, or other jewelry which may get caught in moving parts. Non-slip footwear is recommended. Wear protective hair covering to contain long hair.
- 11. ALWAYS USE SAFETY GLASSES.** Also use face or dust mask if cutting operation is dusty. Everyday eyeglasses only have impact resistant lenses, they are NOT safety glasses.
- 12. SECURE WORK.** Use clamps or a vise to hold work when practical. It's safer than using your hand and frees both hands to operate tool.
- 13. DO NOT OVERREACH.** Keep proper footing and balance at all times.
- 14. MAINTAIN TOOLS WITH CARE.** Keep tools sharp and clean for best and safest performance. Follow instructions for lubricating and changing accessories.
- 15. USE RECOMMENDED ACCESSORIES.** Consult the owner's manual for recommended accessories. The use of improper accessories may cause risk of injury.

- 16. REDUCE THE RISK OF UNINTENTIONAL STARTING.** On machines with magnetic contact starting switches there is a risk of starting if the machine is bumped or jarred. Always disconnect from power source before adjusting or servicing. Make sure switch is in OFF position before reconnecting.

- 17. MANY WOODWORKING TOOLS CAN "KICKBACK" THE WORKPIECE** toward the operator if not handled properly. Know what conditions can create "kickback" and know how to avoid them. Read the manual accompanying the machine thoroughly.

- 18. CHECK DAMAGED PARTS.** Before further use of the tool, a guard or other part that is damaged should be carefully checked to determine that it will operate properly and perform its intended function. Check for alignment of moving parts, binding of moving parts, breakage of parts, mounting, and any other conditions that may affect its operation. A guard or other part that is damaged should be properly repaired or replaced.

- 19. NEVER LEAVE TOOL RUNNING UNATTENDED. TURN POWER OFF.** Do not leave tool until it comes to a complete stop.

- 20. NEVER OPERATE A MACHINE WHEN TIRED, OR UNDER THE INFLUENCE OF DRUGS OR ALCOHOL.** Full mental alertness is required at all times when running a machine.

- 21. NEVER ALLOW UNSUPERVISED OR INEXPERIENCED PERSONNEL TO OPERATE THE MACHINE.** Make sure any instructions you give in regards to machine operation are approved, correct, safe, and clearly understood.

- 22. IF AT ANY TIME YOU ARE EXPERIENCING DIFFICULTIES** performing the intended operation, stop using the machine! Then contact our service department or ask a qualified expert how the operation should be performed.

WARNING

Additional Safety Instructions For Drill Presses

1. **ALWAYS OPERATE YOUR DRILL PRESS AT SPEEDS** that are appropriate for the drill bit size and the material that you are drilling.
2. **FEED THE DRILL BIT EVENLY INTO THE WORKPIECE.** Back the bit out of deep holes and clear the chips with a brush after you have turned the machine off.
3. **MAKE SURE THE DRILL BIT YOU ARE USING IS TIGHTENED PROPERLY.** Use only round, hex or triangular shank drill bits.
4. **NEVER DO MAINTENANCE OR CHANGE SPEEDS WITH THIS MACHINE PLUGGED IN.**
5. **NEVER USE TOOLS THAT ARE IN POOR CONDITION.** Cutting tools that are dull or damaged are difficult to control and may cause serious injury.
6. **NEVER DRILL SHEET METAL UNLESS IT IS CLAMPED SECURELY TO THE TABLE.**
7. **WORK SHOULD BE POSITIONED IN SUCH A WAY AS TO AVOID DRILLING INTO THE TABLE.**
8. **A FACE SHIELD USED WITH SAFETY GLASSES IS RECOMMENDED.**
9. **ALWAYS CLAMP WORKPIECE SECURELY TO TABLE BEFORE DRILLING.** Never hold a workpiece by hand while drilling.
10. **HABITS – GOOD AND BAD – ARE HARD TO BREAK.** Develop good habits in your shop and safety will become second-nature to you.
11. **REMOVE ADJUSTING KEYS AND WRENCHES.** Before turning the machine on, make it a habit to check that all adjusting keys and wrenches have been removed.

CAUTION

No list of safety guidelines can be complete. Every shop environment is different. Always consider safety first, as it applies to your individual working conditions. Use this and other machinery with caution and respect. Failure to do so could result in serious personal injury, damage to equipment or poor work results.

SECTION 2: CIRCUIT REQUIREMENTS

110V Operation

The Model G7945/46 is wired for 110V, single phase operation only. The ½ HP motor will safely draw 5 amps at 110V. If you operate this machine on any circuit that is already close to its capacity, it might blow a fuse or trip a circuit breaker. However, if an unusual load does not exist and a power failure still occurs, contact a qualified electrician or our service department.

A 10-amp fuse or circuit breaker should be used when fusing this drill press. Circuits breakers rated any higher may not be adequate to protect the circuit from power surges.



Extension Cords

If you find it necessary to use an extension cord with the Model G7945/7946, make sure the cord is rated Hard Service (grade S) or better. Refer to the chart in the standard safety instructions to determine the minimum gauge for the extension cord. The extension cord must also contain a ground wire and plug pin.



Grounding

In the event of an electrical short, grounding reduces the risk of electric shock by providing electric current a path of least resistance. This tool is equipped with a power cord having an equipment-grounding conductor. **See Figure 1.** The outlet must be properly installed and grounded in accordance with all local codes and ordinances.

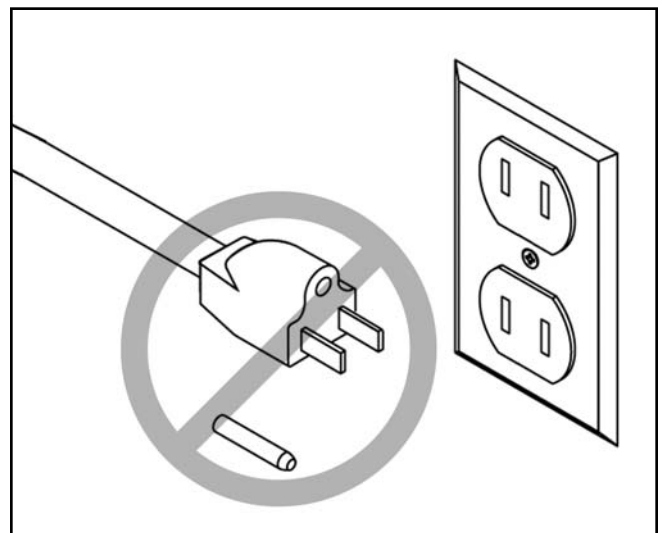
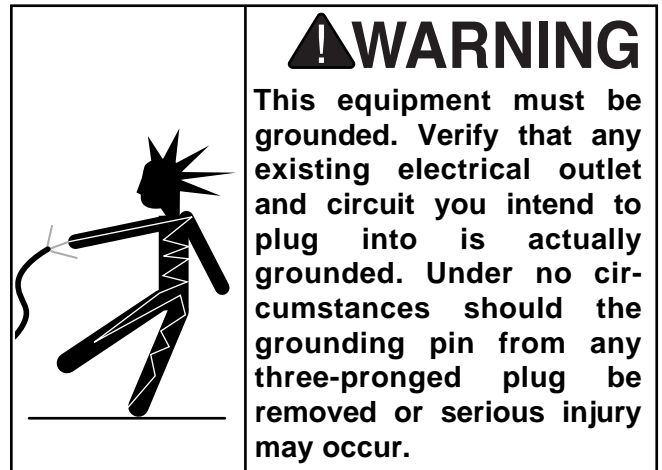

Figure 1A. Do not remove grounding pin.

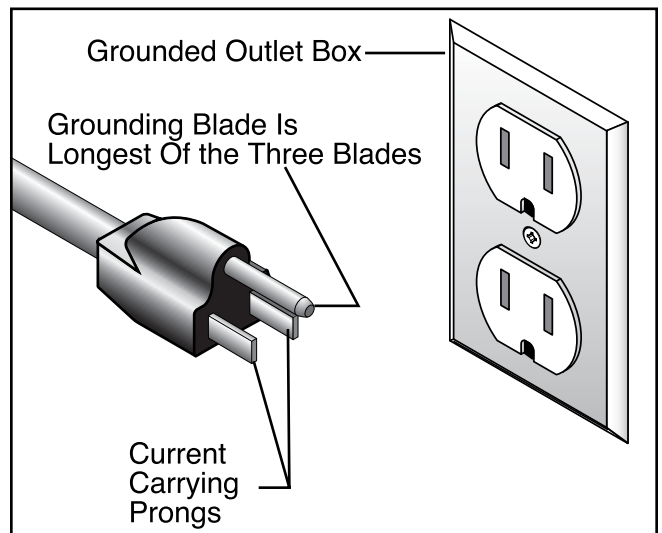

Figure 1. Typical 110V 3-prong plug and outlet.



SECTION 3: INTRODUCTION

Commentary

We are proud to offer the Grizzly Model G7945/46 Radial Drill Press. The Model G7945/46 is part of a growing Grizzly family of fine woodworking machinery. When used according to the guidelines set forth in this manual, you can expect years of trouble-free, enjoyable operation and proof of Grizzly's commitment to customer satisfaction.

The Model G7945/46 is a five speed radial drill press that features variable swing up to 34" and pivoting head for drilling at just about any angle. A ½ H.P. motor powers the drill press from 550 to 3470 R.P.M. to handle a wide variety of drilling needs. The table tilts 90° in both directions and swings 360°. The Model G7946 is exactly the same as the Model G7945, but adds the double pivot table support as well as being a floor model.

A number of bits, sanding drums, and other accessories are available for the Model G7945/46 through the Grizzly catalog.

We are also pleased to provide this manual with the Model G7945/46. It was written to guide you through assembly, review safety considerations, and cover general operating procedures. It represents our effort to produce the best documentation possible. If you have any comments regarding this manual, please write to us at the address below:

Grizzly Industrial, Inc.
% Technical Documentation
P.O. Box 2069
Bellingham, WA 98227-2069

Most importantly, we stand behind our machines. If you have any service questions or parts requests, please call or write us at the location listed below.

Grizzly Industrial, Inc.
2406 Reach Road
Williamsport, PA 17701
Phone: (570) 546-9663
Fax: (800) 438-5901
E-Mail: techsupport@grizzly.com
Web Site: <http://www.grizzly.com>

After fall 2001:
Grizzly Industrial, Inc.
1203 Lycoming Circle
Pennsdale, PA 17756

The specifications, drawings, and photographs illustrated in this manual represent the Model G7945/46 as supplied when the manual was prepared. However, owing to Grizzly's policy of continuous improvement, changes may be made at any time with no obligation on the part of Grizzly. Whenever possible, though, we send manual updates to all owners of a particular tool or machine. Should you receive one, we urge you to insert the new information with the old and keep it for reference.

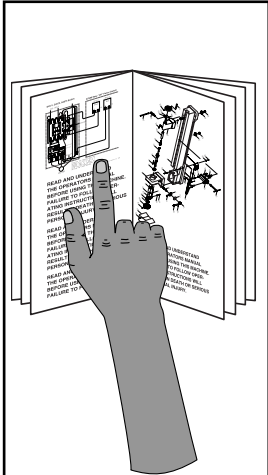
	<p>!WARNING</p> <p>Read the manual before assembly and operation. Become familiar with the machine and its operation before beginning any work. Serious personal injury may result if safety or operational information is not understood or followed.</p>
--	--



Unpacking

The Model G7945/46 is shipped from the manufacturer in a carefully packed carton. If you discover the machine is damaged after you've signed for delivery, immediately call Customer Service for advice.

When you are completely satisfied with the condition of your shipment, you should inventory its parts.

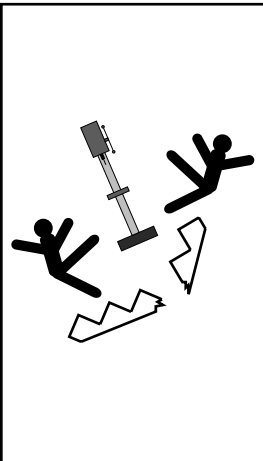
	<p>⚠ WARNING</p> <p>If moving this machine up or down stairs, the machine must be dismantled and moved in smaller pieces. Make sure floor and stair structures are capable of supporting the combined weight of the machine parts and the people moving them.</p>
---	--

	<p>⚠ CAUTION</p> <p>The G7945/7946 represents a heavy load at 100/150 pounds. Seek assistance before beginning assembly.</p>
---	---



Piece Inventory

After all the parts have been removed from the carton, you should have:

- Headstock
- Base
- Column
- Table
- Column Lock
- Drill Chuck and Key
- Spindle Handles (3)
- Allen® Wrenches (2)
- Handle

- Pinion Gear
- Lock Handles (4, 5 for G7946)
- Rack
- Column Ring
- Hardware Bag

In the event that any nonproprietary parts are missing (e.g. a nut or a washer), we would be glad to replace them, or, for the sake of expediency, replacements can be obtained at your local hardware store.

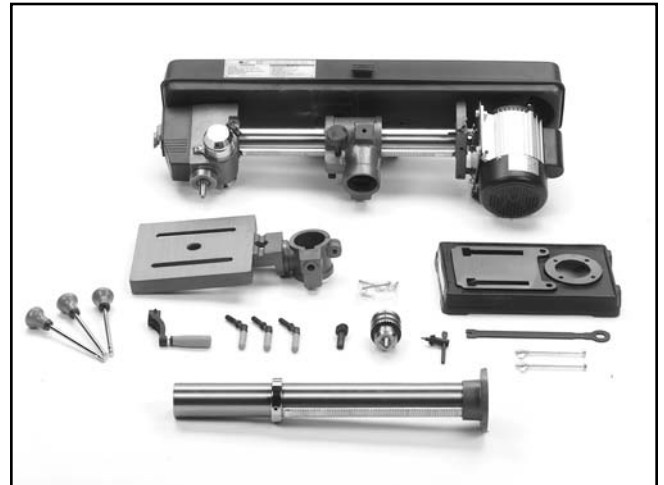

Figure 2. G7945 layout.



Figure 2A. G7946 layout.

NOTICE

A full parts list and breakdown can be found toward the end of this manual. For easier assembly, or to identify specific parts, please refer to the detailed illustrations at the end of the manual.



Clean Up

The unpainted surfaces are coated with a waxy oil to protect them from corrosion during shipment. Remove this protective coating with a solvent cleaner or citrus-based degreaser such as Grizzly's G7895 Degreaser. Avoid chlorine-based solvents as they may damage painted surfaces should they come in contact. Always follow the usage instructions on the product you choose for clean up.

	<p>⚠ WARNING Do not use gasoline or other petroleum-based solvents. They have low flash points which make them extremely flammable. A risk of explosion and burning exists if these products are used. Serious personal injury may occur if this warning is ignored.</p>
---	---

<p>⚠ CAUTION Many of the solvents commonly used to clean machinery can be toxic when inhaled or ingested. Always work in well-ventilated areas far from potential ignition sources when dealing with solvents. Use care when disposing of waste rags and towels to be sure they do not create fire or environmental hazards. Keep children and animals safely away when cleaning and assembling this machine.</p>
--

	<p>⚠ WARNING Do not smoke while using solvents. A risk of explosion or fire exists and may result in serious personal injury.</p>
---	--



Site Considerations

FLOOR LOAD

Your Model G7945/46 represents a moderate weight load in a small footprint. Most commercial or home shop floors should be sufficient to carry the weight of the Model G7945/46. If you question the strength of your floor, you can opt to reinforce it. Ensure that the stand or bench you use with the Model G7945 is capable of supporting the machine.

WORKING CLEARANCES

Working clearances can be thought of as the distances between machines and obstacles that allow safe operation of every machine without limitation. Consider existing and anticipated machine needs, size of material to be processed through each machine, and space for auxiliary stands and/or work tables. Be sure to allow yourself sufficient room to safely run your machines in any foreseeable operation.

LIGHTING AND OUTLETS

Lighting should be bright enough to eliminate shadow and prevent eye strain. Electrical circuits should be dedicated or large enough to handle combined motor amp loads. Outlets should be located near each machine so power or extension cords are not obstructing high-traffic areas. Be sure to observe local electrical codes for proper installation of new lighting, outlets, or circuits.

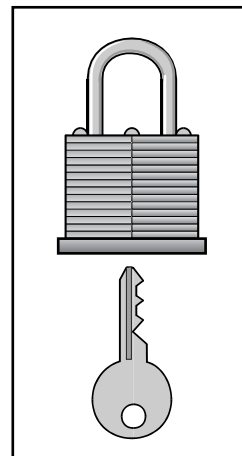
	<p>⚠ CAUTION Make your shop "child safe." Ensure that your workplace is inaccessible to youngsters by closing and locking all entrances when you are away. Never allow visitors in your shop when assembling, adjusting or operating equipment.</p>
--	--



SECTION 4: ASSEMBLY

Beginning Assembly

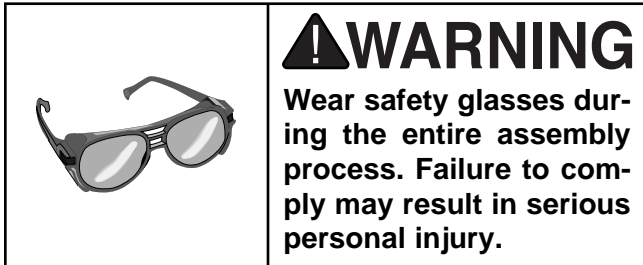
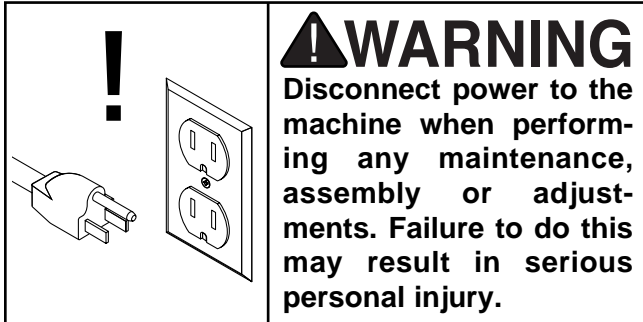

Most of your Model G7945/46 Radial Drill Press has been assembled at the factory, but some parts must be assembled or installed after delivery. We have organized the assembly process into steps. Please follow along in the order presented here.

TOOLS REQUIRED: $1\frac{1}{16}$ " open end wrench, rubber or wooden mallet and a 5mm Allen® wrench (supplied).



Column/Base

The Model G7946 is a floor model and must be secured to the floor using anchor bolts or the base should be secured to a piece of plywood. The G7945 must be secured to a bench.

G7945/46 Radial Drill Press



Figure 3. Attaching plywood sub-base.

1. Unplug machine before assembly.

2. Model G7946

Secure the base to the floor using the appropriate anchor bolts.

or

Secure base to a piece of 4' x 4' x $\frac{3}{4}$ " plywood. Using the holes in the base as a guide, drill and bolt the base to the back center of the plywood using carriage bolts. See **Figure 3**.

2. Model G7945

Secure base to a bench top capable of holding approximately 100 lbs plus the weight of the workpiece. Using the holes in the base as a guide, drill and bolt the base to the bench top using carriage bolts.

3. Place the column on the base and line up the mounting holes. Insert and tighten the M10-1.5 x 40mm hex head bolts with a wrench.



Table Support

The Model G7945 comes with a one piece square table and support as shown in **Figure 4**. The Model G7946 comes with a round table and two piece hinged table support.

1. Insert the pinion gear into the hole on the side of the bracket from the inside, starting with the shaft. See **Figure 5**. Align the setscrew in the crank with the flat portion of the pinion gear shaft. Secure with a 3mm Allen® wrench.
2. The rack has teeth that extend farther on one end than the other. This end must be positioned down. Insert the rack into the table support bracket and position in the pocket. Be sure that the gear teeth are positioned out. See **Figure 6**.
3. While holding the rack in place, slide the table support bracket over the column. Allow the bracket and rack to slide down the column until the bottom of the rack contacts the shoulder of the column support. Secure the table bracket by tightening the lock handle.
4. Slide the column ring onto the top end of the column with the inside bevel downward. See **Figure 7**. Move the ring around until the tip of the rack fits inside the bevel.

NOTICE

Do not over-tighten the setscrew in the column ring, as it may split the ring.



Figure 4. G7945 table and support.

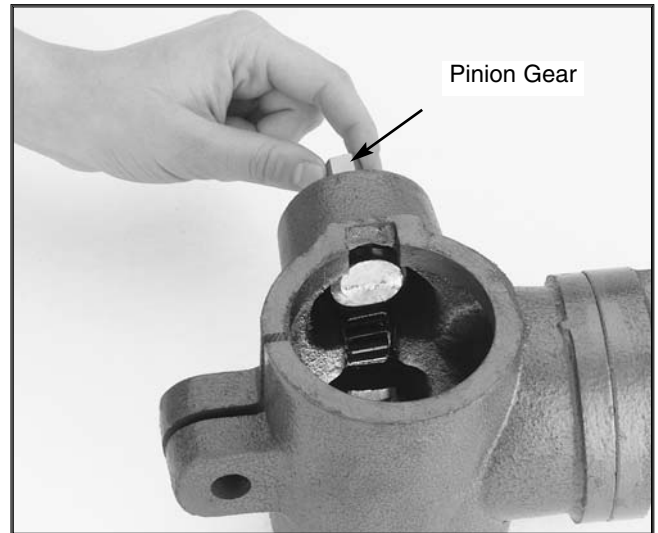

Figure 5. Insert the pinion gear from the inside.



Figure 6. Rack orientation (G7946 shown).



Figure 7. Inside bevel in the correct position.



Headstock

1. Make sure the locking gib is in the recessed pocket on the inside edge of the headstock opening. See **Figure 8**.
2. With the help of an assistant, lift the headstock over the top end of the column. When the underside of the headstock is lined up with the column, slide the headstock onto the column until it stops (approximately 2").
3. Screw two lock handles into each side of the headstock bracket. See **Figure 8**.

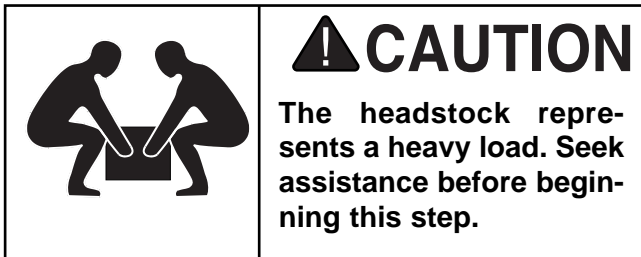

Figure 8. Lock Handles and gib location.



Handles

Three handles are supplied with the drill press. Thread them into the handle hub.



Drill Chuck and Arbor

The drill chuck is attached to the drill spindle by means of a machined taper between the chuck and spindle nose. An almost permanent assembly is created when properly joined. To assemble the drill chuck and mount it to the spindle, carefully follow the instructions below:

1. The drill chuck and spindle must be thoroughly cleaned and dried before assembly. It is recommended that mineral spirits be used for this task. Refer to the safety warnings on the container of the mineral spirits. **Failure to clean the mating surfaces may result in separation, and an unsafe condition. Separation is usually a result of oil or grease on the taper.**
2. Use the chuck key provided to adjust the jaws of the chuck until they are well inside the drill chuck body.
3. Slide the chuck onto the spindle end and tap the end of the drill chuck with a rubber or wooden mallet to seat it. See **Figure 9**.

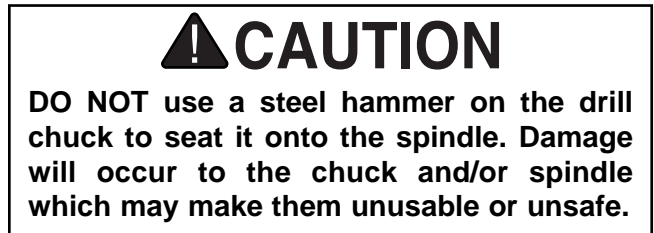
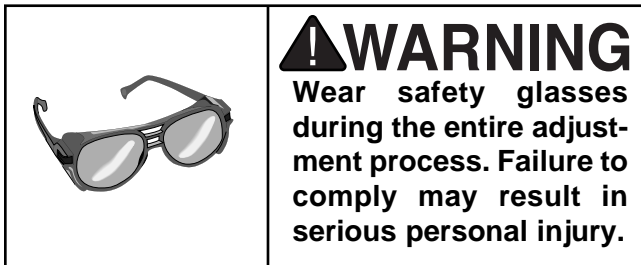
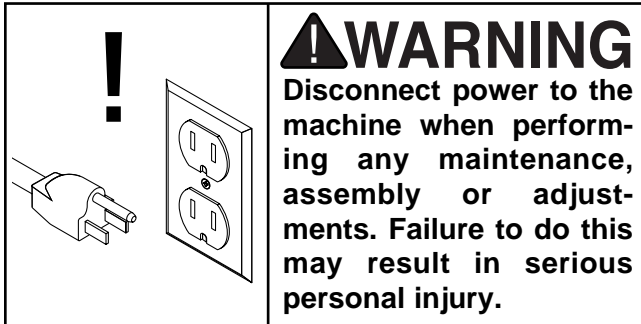

Figure 9. Seating chuck into spindle. (Note retracted jaws.)



SECTION 5: ADJUSTMENTS

Speed Change



Unplug the drill press before changing speeds. The drill press has 5 speeds ranging from 550 to 3470 R.P.M. There is a speed chart located under the belt guard. Refer to this chart when setting a speed.

1. Loosen the belt tension lock knob on the side of the headstock. See **Figure 10**.
2. Pivot the motor to take tension off the V-belt.
3. Determine the desired speed on the chart and move the V-belt to the desired V-grooves on the motor and spindle pulleys.

4. Pivot the motor toward the back of the headstock, the motor support rod is spring loaded and will follow the motor. Tighten the lock knob once the desired V-belt tension is achieved.
5. Close the cover.



Figure 10. Loosening the lock knob.



Depth Stop

Your radial drill press comes with a depth stop for use when drilling. Follow the instructions below for use.

1. Loosen the depth collar lock knob. See **Figure 11**.
2. Secure the wood stock you will be drilling onto the drill press table.
3. With the desired bit installed, lower the spindle until the tip of the bit just touches the wood stock you will be drilling. Hold the spindle in this position.
4. Turn the depth collar to the desired depth indicated by the scale on the collar. Secure the collar by tightening the lock knob.
3. Remove the wood stock and test the depth stop by measuring how far the spindle travels when the handles are rotated. See **Figure 12**.



Figure 11. Loosening collar lock knob.

You can also lock the spindle in the down position for operations such as spindle sanding.

1. Loosen the depth collar lock knob. See **Figure 11**.
2. Rotate the spindle to the desired depth and hold it steady.
3. Rotate the the collar clockwise until it stops, and tighten the lock knob.
4. Slowly release the drill press handle and the spindle should not move.



Figure 12. Actual stop depth being measured.



Table Adjustments

The Model G7945 table can be adjusted for height and angle. The G7946 adds the adjustments of table distance from column and rotation. Follow these instructions to adjust height:

1. Loosen the table support bracket lock handle. Turn the table hand crank to lift or lower the table.
2. Remember to lock the support bracket in place before operating the machine.

Adjust angle: (Model G7946 only).

1. Turn the nut shown by the arrow in **Figure 13**, in a clockwise direction. This will draw the location pin out of the casting. Once loose, pull out the pin and nut, and set them in a safe place until needed.
2. Loosen the large bolt in the center of the support bracket. See **Figure 13**.
3. Using the scale on the side of the bracket or a protractor to set the angle, rotate the bracket to the desired angle. Lock in place by tightening bolt.

Adjust rotation (Model G7946 Only):

1. Loosen the lock handle located under the table. Rotate the table the desired amount.
2. Always lock the support bracket in place before operating the machine.

Adjusting distance from column (G7946 Only):

1. Loosen the lock handle located at the pivoting elbow of the table support. See **Figure 15**.
2. Swing the table support to the desired distance from the column. The support bracket may need to be rotated around the column to keep the table centered under the chuck. Secure all lock handles before operating the machine.

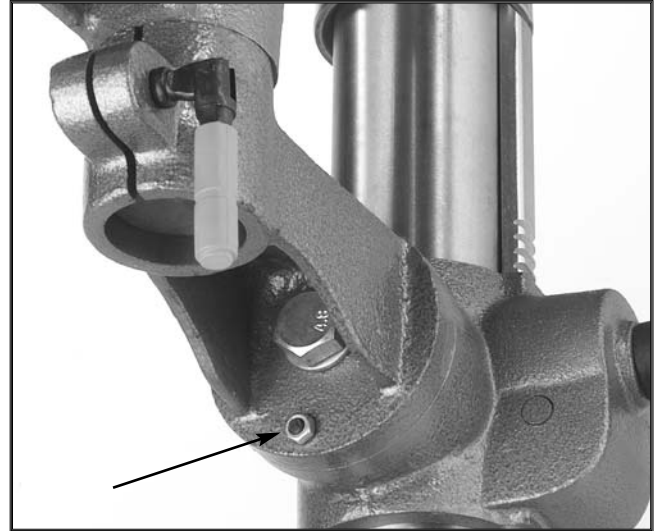

Figure 13. Locating pin and nut (G7946).

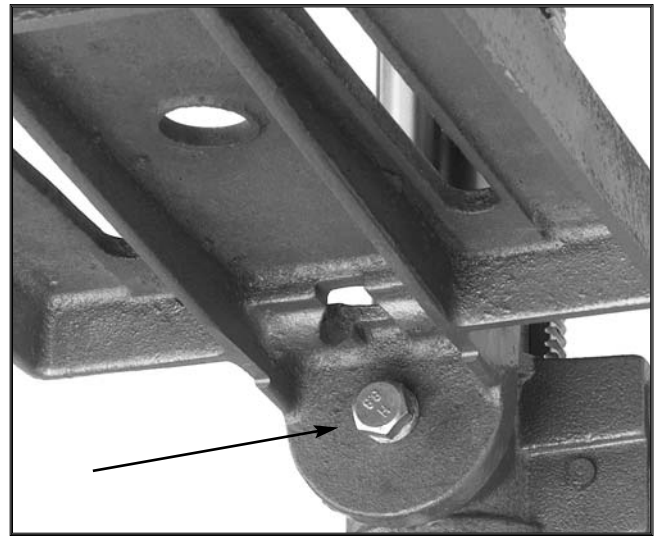

Figure 14. Angle adjustment bolt (G7945).

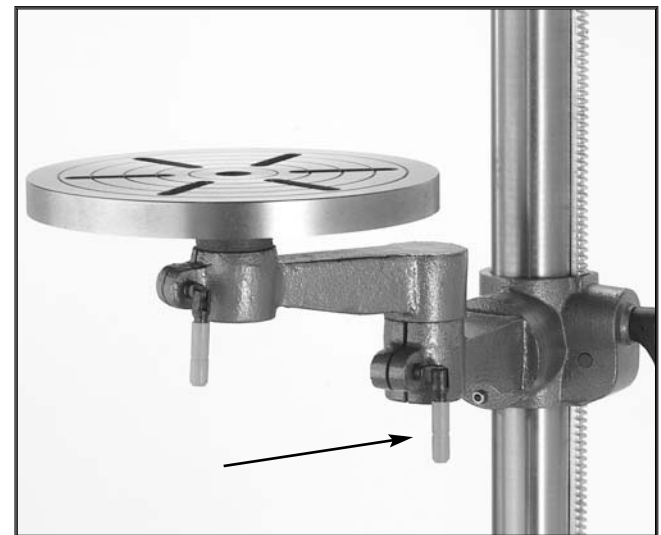

Figure 15. Adjusting distance from column.



Head Adjustments

The headstock can be tilted from 45° clockwise to 90° counterclockwise.

1. Loosen the lock handle on the right side of the headstock.
2. Pull out the guide pin located on the left side of the headstock and rotate the pin 90°. See **Figure 16**. Tilt the headstock to the desired angle specified on the scale and tighten the lock handle on the right side of the headstock.

Return to vertical position:

1. Loosen the lock handle located on the right side of the headstock.
2. Move the headstock to its original position and move the guide pin back into the guide slot. Tighten the lock handle.

The headstock can also be adjusted back and forth:

1. Loosen the lock handle located on the right side of the headstock.
2. Turn the black ribbed handle to move the headstock back and forth to desired position. Tighten the lock handle before operating the machine.

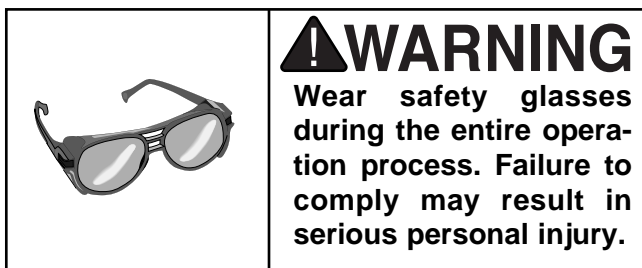
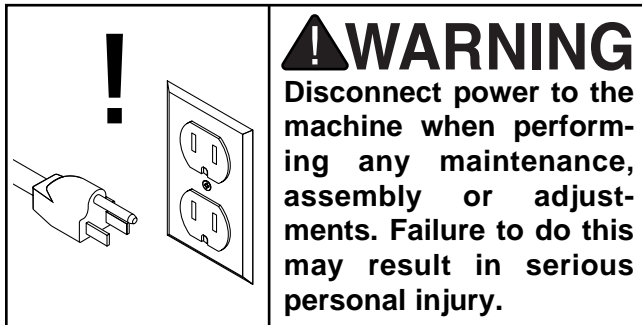

Figure 16. Guide pin location.



SECTION 6: OPERATIONS

Test Run



Once assembly is complete and adjustments are done to your satisfaction, you are ready to test run the machine.

Turn on the power supply at the main panel. Press the START button. Make sure that your finger is poised on the paddle switch, just in case there's a problem. The drill press should run smoothly, with little or no vibration or rubbing noises. Strange or unnatural noises should be investigated and corrected before operating the machine further.

If you cannot easily locate the source of an unusual noise or vibration, contact our service department for help.



Drill Bit Changes

Care must be taken to secure the bit firmly in place. When changing bits, proceed as follows:

1. Disconnect the machine from the power source.
2. Open the chuck wide enough to accept a new bit.
3. Install the bit so the chuck jaws will grab as much of the bit shank as possible. Do not allow the chuck to grab the fluted body of the drill bit. Make sure small drill bits do not get trapped between the edges of two jaws.
4. Tighten the chuck with the chuck key using any of the three key end locations.
5. Remove the chuck key and reconnect the power source.
6. Reverse steps to remove the drill bit.



SECTION 7: MAINTENANCE

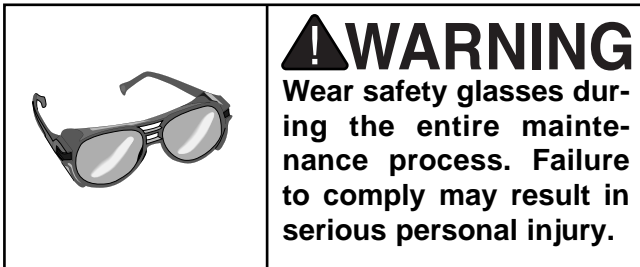
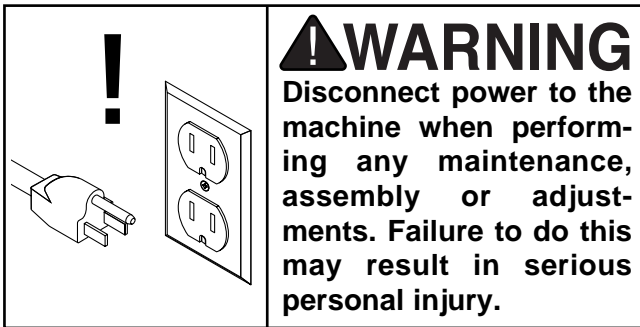

General

Regular periodic maintenance on your Model G7945/46 will ensure its optimum performance. Make a habit of inspecting your machine each time you use it. Check for the following conditions and repair or replace when necessary:

1. Loose mounting bolts.
2. Worn switch.
3. Worn or damaged cords and plugs.
4. Damaged V-belt.
5. Any other condition that could hamper the safe operation of this machine.



Tables

The nonpainted surfaces on the Model G7945/46 should be protected against rust and pitting. Wiping the machine clean after every use ensures that wood dust will not trap moisture against bare metal surfaces.

Some woodworkers recommend using automotive paste wax on exposed steel and cast iron surfaces. The wax provides a layer of protection, as well as reducing friction between lumber and the table, making cuts faster and smoother. Avoid waxes that contain silicone or other synthetic ingredients. These materials can find their way into lumber that is being worked, and can make staining and finishing difficult. If you use paste wax, make sure that it is 100% Carnuba wax.



Lubrication

Since all bearings are shielded and permanently lubricated, simply leave them alone until they need to be replaced. Do not lubricate them.



V-Belt

Inspect regularly for tension and wear. Check pulleys to ensure that they are properly aligned. See pulley/V-belt sections for proper tension and pulley alignment procedures.



SECTION 8: CLOSURE

The following pages contain general machine data, parts diagrams/lists, a troubleshooting guide and Warranty/Return information for your Model G7945/46 Radial Drill Press.

If you need parts or help in assembling your machine, or if you need operational information, we encourage you to call our Service Department. Our trained service technicians will be glad to help you.

If you have comments dealing specifically with this manual, please write to our Bellingham, Washington location using the address in **Section 3 Introduction**.

We have included some important safety measures that are essential to this machine's operation. While most safety measures are generally universal, Grizzly reminds you that each workshop is different and safety rules should be considered as they apply to your specific situation.

WARNING

Operating this equipment has the potential for flying debris to cause eye injury. Always wear safety glasses or goggles when operating equipment. Everyday glasses or reading glasses only have impact resistant lenses, they are not safety glasses. Be certain the safety glasses you wear meet the appropriate standards of the American National Standards Institute (ANSI).



We recommend you keep a copy of our current catalog for complete information regarding Grizzly's warranty and return policy. If you need additional technical information relating to this machine, or if you need general assistance or replacement parts, please contact the Service Department listed in **Section 3: General Information**.

Additional information sources are necessary to realize the full potential of this machine. Trade journals, woodworking magazines, and your local library are good places to start.

WARNING

The Model G7945/46 was specifically designed for drilling operations. **DO NOT MODIFY AND/OR USE THIS MACHINE FOR ANY OTHER PURPOSE.** Modifications or improper use of this tool will void the warranty. If you are confused about any aspect of this machine, **DO NOT** use it until all your questions have been answered or serious personal injury may occur.

WARNING

Like all power tools, there is danger associated with the Model G7945/46. Accidents are frequently caused by lack of familiarity or failure to pay attention. Use this tool with respect and caution to lessen the possibility of operator injury. If normal safety precautions are overlooked or ignored, serious personal injury may occur.





MACHINE DATA SHEET

Customer Service #: (570) 546-9663 • To Order Call: (800) 523-4777 • Fax #: (800) 438-5901

GRIZZLY MODEL G7945 RADIAL DRILL PRESS

Design TypeBench Model

Overall Dimensions:

Table8⁵/₈" x 9"
Overall Height31¹/₂"
Overall Width11¹/₂"
Overall Depth33¹/₂"
Column Diameter2.360"
Quill Diameter..... 0.575"
Shipping Weight.....100 lbs.
Box Size.....34¹/₂" L x 18" W x 12¹/₂" H
Footprint13¹/₂" x 8¹/₂"

Construction:

TablePrecision Ground Cast Iron
Column.....Cylindrical Ground Steel
Base & HeadCast Iron

Capacities:

Spindle Travel.....3¹/₄"
Max. Distance, Spindle to Base19"
Max. Distance, Spindle to Table.....14¹/₂"
Spindle NoseB-16
Swing34"
Chuck Size⁵/₈" (16mm), keyed
Speeds5, Belt Controlled
Range of Speeds550, 880, 1520, 2490, 3470 R.P.M.
Head Radial Movement12¹/₂"
Head Radial Pivot.....45° Clockwise, 90° Counter-Clockwise, Positive Stop @ 90°
Drilling Capacity.....¹/₂" Diameter in Steel

Motor:

TypeTEFC Capacitor Start Induction
Horsepower¹/₂ H.P.
Phase/CycleSingle Phase/60 Hz
Amps.....5
Voltage110V
R.P.M.....1720
Power Transfer..... V-Belt Drive
BearingsShielded & Lubricated Ball Bearings
SwitchToggle ON/OFF w/ Safety Lock Tab

Features:

Table360° Swivel Around Support Column,Tilt -90° to + 90°, Lock Levers
Vertical Table MovementCrank Handle Operated Rack and Pinion
Slots.....2 slots, ⁵/₈" x 6"
Depth GaugeOn Feed Handle Hub, Inch Increments

Specifications, while deemed accurate, are not guaranteed.



MACHINE DATA SHEET

Customer Service #: (570) 546-9663 • To Order Call: (800) 523-4777 • Fax #: (800) 438-5901

GRIZZLY MODEL G7946 FLOOR RADIAL DRILL PRESS

Design TypeFloor Model

Overall Dimensions:

Table12³/₁₆" Round
 Overall Height.....64¹/₂"
 Overall Width.....14"
 Overall Depth.....32"
 Column Diameter2.790" (Vertical), 2.356" (Horizontal)
 Quill Diameter 0.575"
 Shipping Weight.....150 lbs.
 Box Size55" L x 20¹/₂" W x 10" H
 Footprint18" x 11"

Construction:

TablePrecision Ground Cast Iron
 Column.....Cylindrical Ground Steel
 Base & HeadCast Iron

Capacities:

Spindle Travel.....3¹/₄"
 Max. Distance, Spindle to Base51"
 Max. Distance, Spindle to Table.....30¹/₂"
 Spindle NoseB-16
 Swing33¹/₂"
 Chuck Size⁵/₈" (16mm), keyed
 Speeds5, Belt Controlled
 Range of Speeds550, 880, 1520, 2490, 3470 R.P.M.
 Head Radial Movement12¹/₂"
 Head Radial Pivot.....45° Clockwise, 90° Counter-Clockwise, Positive Stop @ 90°
 Drilling Capacity.....¹/₂" Diameter in Steel

Motor:

TypeTEFC Capacitor Start Induction
 Horsepower¹/₂ H.P.
 Phase / CycleSingle Phase / 60 Hz
 Voltage110V
 Amps.....5
 R.P.M.1720
 Power TransferV-Belt Drive
 BearingsShielded & Lubricated Ball Bearings
 SwitchToggle ON/OFF w/ Safety Lock Tab

Features:

Table .360° Swivel Around Table Center, 270° Swivel Around Pivot 6" from Column,
 360° Swivel Around Support Column, Tilt -90° to + 90°, Lock Levers
 Vertical Table MovementCrank Handle Operated Rack and Pinion
 Slots.....6 radial slots, ⁵/₈" x 3¹/₄"
 Depth GaugeOn Feed Handle Hub, Inch Increments

Specifications, while deemed accurate, are not guaranteed.

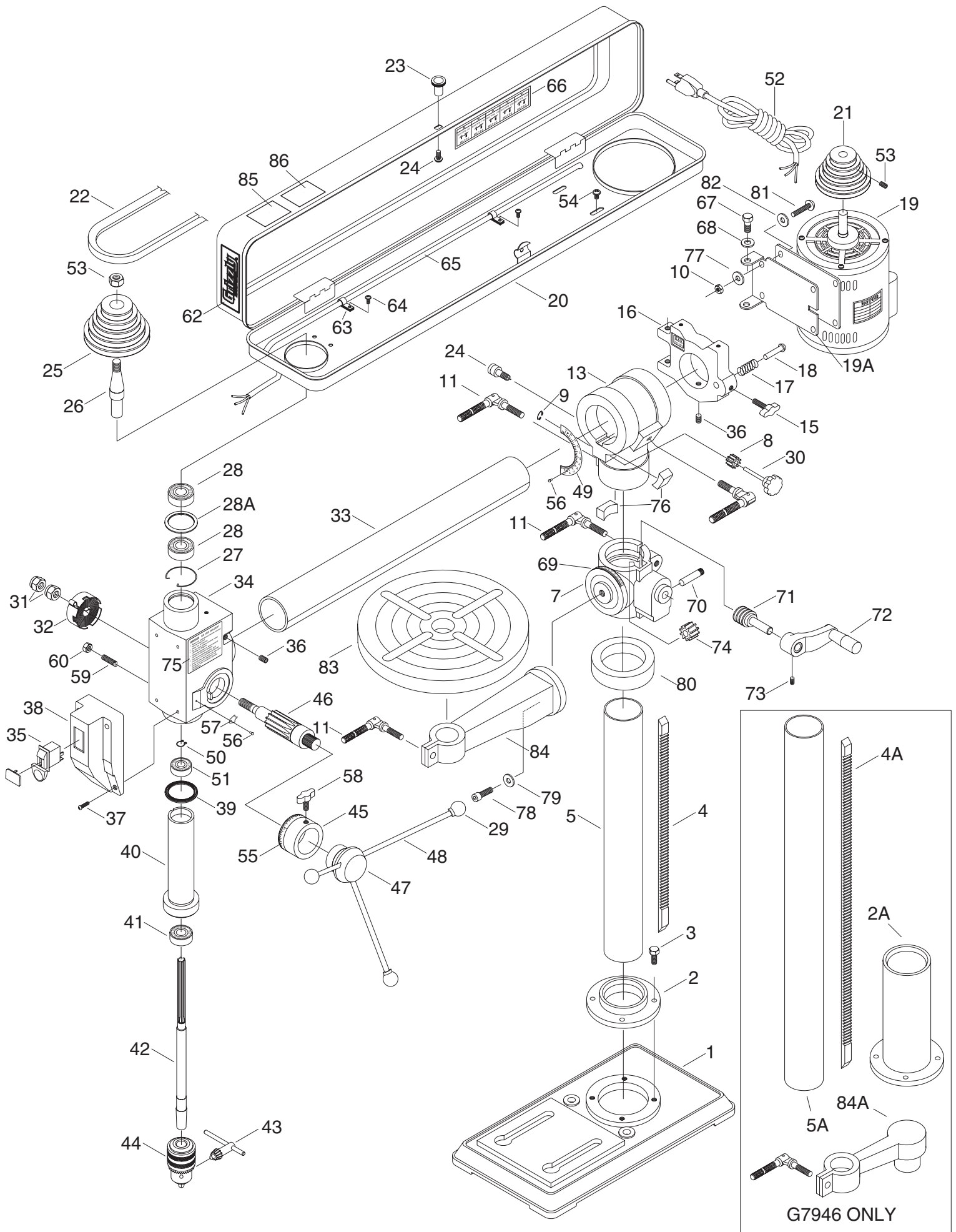

Ref#	Part#	Description
001	P7945001	BASE
002	P7945002	FLANGE
002A	P7946002A	W1670 FLANGE
003	PB07	HEX BOLT 5/16"-18X3/4"
004	P7945004	RACK
004A	P7945004A	LONG RACK
005	P7945005	VERT. COLUMN
005A	P7945005A	LONG VERT. COLUMN
007	P7945007	TABLE SUPPORT BRACKET
008	P7945008	GEAR
009	P7945009	RETAINER RING
010	P7945010	HEX NUT
011	P7945011	CLAMP BOLT
012	P7945012	LCK HANDLE ASSY
013	P7945013	COLUMN BRACKET
014	PSS02	SETSCREW 5/16"-18X3/8"
015	P7945015	LOCK KNOB
016	P7945016	MOUNT PLATE
017	P7945017	SPRING
018	P7945018	ADJUSTMENT BOLT
019	P7945019	MOTOR
019A	P7945019A	MOTOR MOUNT BRACKET
020	P7945020	PULLEY COVER
021	P7945021	MOTOR PULLEY
022	P7945022	V-BELT
023	P7945023	KNOB
024	P7945024	LOCK PIN
025	P7945025	SPINDLE PULLEY
026	P7945026	DRIVE SLEEVE
027	P7945027	40M RETAINING RING
028	PB203	6203-2RS BEARING
028A	P7945028A	SPACER
029	P7945029	KNOB
030	P7945030	HORIZONTAL ADJ KNOB
031	PLN08	1/2"-20 LOCK NUT
032	P7945032	COVER WITH SPRING
033	P7945033	HORIZONTAL COLUMN
034	P7945034	HEADSTOCK
035	P7945035	SWITCH
036	PSS02	SETSCREW 5/16"-18X3/8"
037	PS22	PHLP SCREW 10-24X5/8"
038	P7945038	SWITCH MOUNT COVER
039	P7945039	RUBBER WASHER
040	P7945040	QUILL
041	PB202	6202-2RS BEARING
042	P7945042	SPINDLE
043	P7945043	CHUCK KEY
044	P7945044	1/2" CHUCK
045	P7945045	SCALE SLEEVE
046	P7945046	PINION

Ref#	Part#	Description
047	P7945047	HUB
048	P7945048	HANDLE
049	P7945049	DEGREE SCALE
050	P7945050	12M RETAINING RING
051	PB201	6201-2RS BEARING
052	P7945052	POWER CORD
053	P7945053	PULLEY SET NUT
054	PS07	PHLP SCREW 1/4"-20X3/8"
055	P7945055	SPINDLE SCALE
056	P7945056	RIVET
057	P7945057	POINTER
058	P7945058	LOCK KNOB
059	P7945059	SPECIAL SETSCREW
060	PN02	HEX NUT 5/16"-18
061	P7945061	HANDLE
062	P7945062	LOGO
063	P7945063	WIRE STRAP
064	PS06	PHLP SCREW 10-24X3/8"
065	P7945065	MOTOR SWITCH CORD
066	P7945066	SPEED CHART
067	P7945067	SPECIAL BOLT
068	PW07	FLAT WASHER 5/16"
069	P7945069	TABLE SCALE
070	P7945070	PIN
071	P7945071	WORM SHAFT
072	P7945072	LIFT HANDLE CRANK
073	PSS01M	SETSCREW M6-1.0X10
074	P7945074	10T GEAR
075	P7945075	SAFETY LABEL
076	P7945076	LOCKING GIB
077	P7945077	WASHER
078	P7945078	10M CAPSCREW
079	PW04M	10M FLATWASHER
080	P7945080	RETAINER RING
081	P7945081	HEX BOLT
082	P7945082	WASHER
083	P7945083	TABLE
084	P7945084	COLUMN SUPPORT
084A	P7945084A	TABLE SUPPORT EXTENSION
85	P7945085	SAFETY GLASSES WARNING
86	P7945086	CLOSE LID WARNING

NOTES

WARRANTY AND RETURNS

Grizzly Industrial, Inc. warrants every product it sells for a period of **1 year** to the original purchaser from the date of purchase. This warranty does not apply to defects due directly or indirectly to misuse, abuse, negligence, accidents, repairs or alterations or lack of maintenance. This is Grizzly's sole written warranty and any and all warranties that may be implied by law, including any merchantability or fitness, for any particular purpose, are hereby limited to the duration of this written warranty. We do not warrant or represent that the merchandise complies with the provisions of any law or acts unless the manufacturer so warrants. In no event shall Grizzly's liability under this warranty exceed the purchase price paid for the product and any legal actions brought against Grizzly shall be tried in the State of Washington, County of Whatcom.

We shall in no event be liable for death, injuries to persons or property or for incidental, contingent, special, or consequential damages arising from the use of our products.

To take advantage of this warranty, contact us by mail or phone and give us all the details. We will then issue you a "Return Number," which must be clearly posted on the outside as well as the inside of the carton. We will not accept any item back without this number. Proof of purchase must accompany the merchandise.

The manufacturers reserve the right to change specifications at any time because they constantly strive to achieve better quality equipment. We make every effort to ensure that our products meet high quality and durability standards and we hope you never need to use this warranty.

Please feel free to write or call us if you have any questions about the machine or the manual.

Thank you again for your business and continued support. We hope to serve you again soon.

WARRANTY CARD

Name _____
Street _____
City _____ State _____ Zip _____
Phone Number _____ E-Mail _____ FAX _____
MODEL # G7945/7946 Radial Drill Press Order # _____

The following information is given on a voluntary basis. It will be used for marketing purposes to help us develop better products and services. Of course, all information is strictly confidential.

- How did you learn about us?
 Advertisement Friend
 Catalog Card Deck
 World Wide Web
 Other _____
- Which of the following magazines do you subscribe to.
 American Woodworker Practical Homeowner
 Cabinetmaker Shop Notes
 Family Handyman Today's Homeowner
 Fine Homebuilding WOOD
 Fine Woodworking Wooden Boat
 Home Handyman Woodshop News
 Journal of Light Construction Woodsmith
 Old House Journal Woodwork
 Popular Mechanics Woodworker
 Popular Science Woodworker's Journal
 Popular Woodworking Workbench
 Other _____
- Which of the following woodworking/remodeling shows do you watch?
 Backyard America The New Yankee Workshop
 Home Time This Old House
 The American Woodworker Woodwright's Shop
 Other _____
- What is your annual household income?
 \$20,000-\$29,999 \$60,000-\$69,999
 \$30,000-\$39,999 \$70,000-\$79,999
 \$40,000-\$49,999 \$80,000-\$89,999
 \$50,000-\$59,999 \$90,000 +
- What is your age group?
 20-29 50-59
 30-39 60-69
 40-49 70 +
- How long have you been a woodworker?
 0 - 2 Years 8 - 20 Years
 2 - 8 Years 20+ Years
- How would you rank your woodworking skills?
 Simple Advanced
 Intermediate Master Craftsman
- What stationary woodworking tools do you own? Check all that apply.
 Air Compressor Panel Saw
 Band Saw Planer
 Drill Press Power Feeder
 Drum Sander Radial Arm Saw
 Dust Collector Shaper
 Horizontal Boring Machine Spindle Sander
 Jointer Table Saw
 Lathe Vacuum Veneer Press
 Mortiser Wide Belt Sander
 Other _____
- How many of your woodworking machines are Grizzly? _____
- Which benchtop tools do you own? Check all that apply.
 1" x 42" Belt Sander 6" - 8" Grinder
 5" - 8" Drill Press Mini Lathe
 8" Table Saw 10" - 12" Thickness Planer
 8" - 10" Bandsaw Scroll Saw
 Disc/Belt Sander Spindle/Belt Sander
 Mini Jointer
 Other _____
- How many of the machines checked above are Grizzly? _____
- Which portable/hand held power tools do you own? Check all that apply.
 Belt Sander Orbital Sander
 Biscuit Joiner Palm Sander
 Circular Saw Portable Planer
 Detail Sander Saber Saw
 Drill/Driver Reciprocating Saw
 Miter Saw Router
 Other _____
- What machines/supplies would you like Grizzly Industrial to carry?
 12" Table Saw Radial Arm Saw
 12" Jointer Panel Saw
 Combination Planer/Jointer Brass Hardware
 Paint & Finishing Supplies Lumber
 Contractor's Supplies
 Other _____
- What new accessories would you like Grizzly Industrial to carry?
 Builders Hardware Hand Tools
 Fasteners Wood Components
 Other _____
- What other companies do you purchase your tools and supplies from?

- Do you think your purchase represents good value?
 Yes No
- Would you recommend Grizzly Industrial to a friend?
 Yes No
- Would you allow us to use your name as a reference for Grizzly customers in your area? **Note: We never use names more than three times.**
 Yes No
- Comments: _____

FOLD ALONG DOTTED LINE

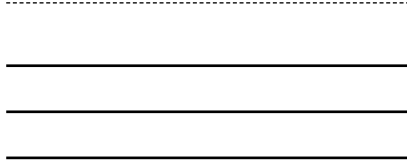

Place
Stamp
Here



**GRIZZLY INDUSTRIAL, INC.
P.O. BOX 2069
BELLINGHAM, WA 98227-2069**



FOLD ALONG DOTTED LINE

Send a Grizzly Catalog to a friend:

Name _____
Street _____
City _____ State _____ Zip _____

TAPE ALONG EDGES--PLEASE DO NOT STAPLE